

INSTALLATION MANUAL

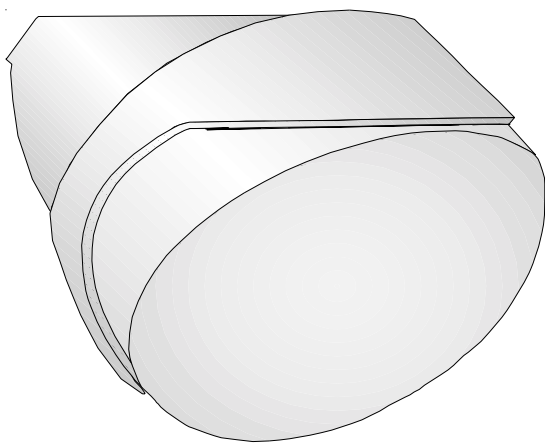

An independent passive infrared detector that simultaneously or individually controls cameras, VCR's, DVR's and all low voltage switching requirements.

The Elite offers a high level of adaptability, there are seven different modes of operation giving various permutations of normally open and normally closed arrangements for the two pairs of volt-free relays, plus a selection of timing and functional options for the relay changeover contacts.

Other programmable parameters include the duration of timed changeover, a pulse count feature and a choice of detection ranges from 10 to 35 metres.

In addition there are two switched negative outputs. The 'A' output gives a single 400ms trigger every time the detector activates and is generally used in conjunction with the GJD lighting controllers to give 24-hour visual and audible alarm indication. The 'S' output is the only photocell-controlled output giving a fixed 60-second trigger on activation.

The flexibility of the four outputs and timers allows the Elite to be used in multiple situations without the need for any further customised equipment.

The integral dual axis tilt sensor allows 180° of pan and 90° tilt. This increases the speed of the outdoor installation and provides incredibly accurate aiming of the detection pattern. The electronics module is acrylic coated for additional component stability. It is encased in a vandal-resistant high impact ABS housing with a UV stabilised translucent front cover ensuring the sensor is impervious to and unaffected by weather conditions.

The Elite's effective design gives a neat appearance with no visible indication of the orientation of the detector head, and totally hides the wiring.

| ELITE SPECIFICATIONS | | |
|------------------------------|--|--|
| Detection Area | 10 to 35 metres (adjustable) up to 750 sq metres | |
| Coverage | 90 degree 35 metres x 30 metres max | |
| Adjustment | 180 degree pan + 90 degree tilt Area reduction mask (if required) | |
| Fresnel Lans | 36 zone - White light filter | |
| Customised Optics | Double silicon shielded dual element eliminates 50,000 lux of white light | |
| Outputs | Silent solid state magnetically immune | |
| No. 1 | CCTV Output | Volt free relay signal contact- 24VAC/DC @ 50mA with an integral 80R series resistor, Selectable normally open/normally closed. Adjustable timer options: 0.4 to 60 seconds |
| No. 2 | Video Output | Volt free relay signal contact- 24VAC/DC @ 50mA. Selectable normally open/normally closed with an integral 80R series resistor. Adjustable timer options: 2 to 60 seconds |
| No. 3 | Output 'A' | Open collector negative switching - 25mA max. Alarm period 400ms |
| No 4. | Output 'S' | Open collector negative switching - 25mA max. Alarm period: detection + 60 seconds Adjustable: Dusk (2 lux) to 24 hour |
| Power input | 9 to 15VDC | |
| Current | 10mA (12V nominal) | |
| Pulse Count | 1 (2, 3 & 4 previous Detection < 6 seconds) | |
| Tamper | Selectable - Mode 1 or 7 plus output opens for 2 seconds when cover removed and/or 'A' & 'S' outputs pulse for 60 seconds | |
| Temp. Compensation | Digital sensitivity adjustment | |
| Control | Digital ASIC/microprocesor - non volatile memory | |
| Walk Test | Output test mode with LED indication | |
| Operating Temp. | -20 to + 55 centigrade Conformally coated electronics for increased stability | |
| Housing | High Impact ABS | |
| Protection Rating | I P 55 | |
| Dimension | 104 x 104 x 94 mm | |
| Weight | 145 grams | |
| Mounting Height | Variable - optimum height 3 metres | |
| Cable < 200 metres | Utilising all four outputs - 8 core 7/0.2mm | |
| Cable < 500 metres | Utilising all four outputs - 8 core 16/0.2mm | |

MULTIBEAM LENS DATA

The GJD multifunction lens fitted to the GJD ELITE detector produces 9 long range beams and 9 medium to short range curtain beams. Movement across the beams produces the best response and range, whilst movement towards the detector will be less responsive.

When mounting higher than boundary fences rotate the module and mask off any beams, either vertically or horizontally, that fall outside the area being covered. Use portions of the self-adhesive clear mask supplied to the rear, smooth side, of the lens and always replace the correct way up as shown to obtain the exact beam pattern coverage.

| | | |
|--|--|--|
| <p>MULTIBEAM - OPTIMUM HEIGHT: 3 METRES RANGE: MAXIMUM MODULE TILT: 0 DEGREE</p> | | |
|--|--|--|

| | | |
|--|--|--|
| <p>MULTIBEAM HEIGHT: 6 METRES RANGE: MAXIMUM MODULE TILT: 9 DEGREE</p> | | |
|--|--|--|

| | | |
|--|--|--|
| <p>PET IMMUNITY HEIGHT: 1.5 METRES RANGE: MAXIMUM MODULE TILT: -2 DEGREE</p> | | |
|--|--|--|

| | | |
|--|--|--|
| <p>CURTAIN COVERAGE HEIGHT: 6 METRES RANGE: MAXIMUM MODULE TILT: 45 DEGREE</p> | | |
|--|--|--|

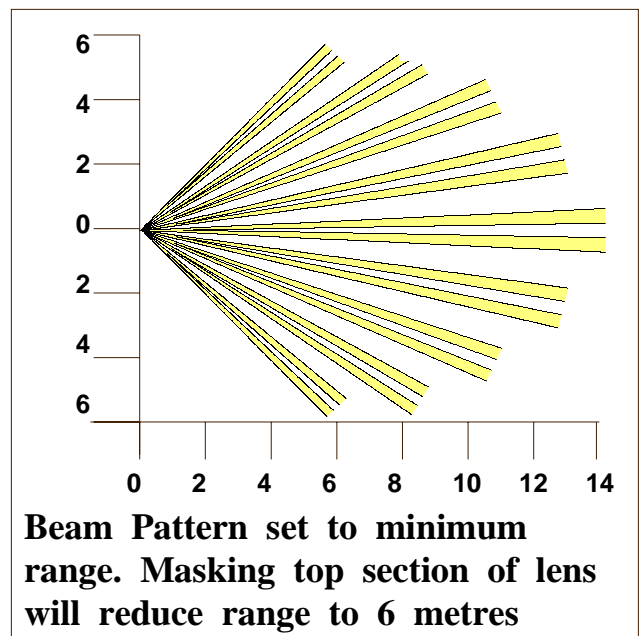
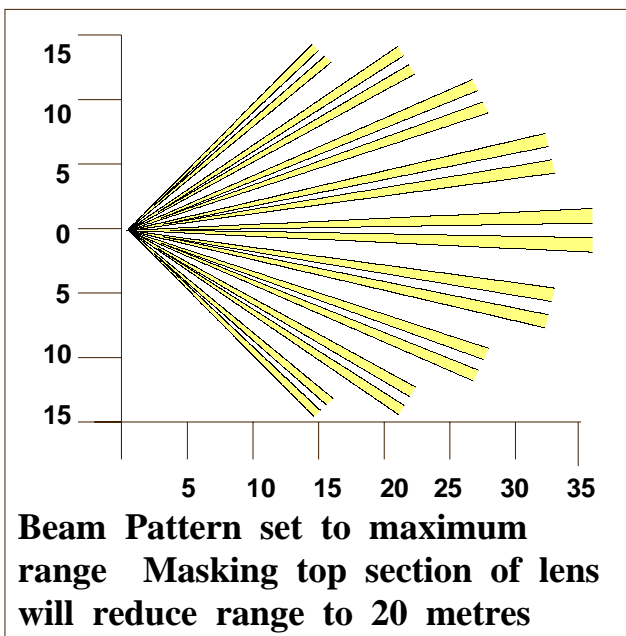

CHANGING THE EXISTING SETTING

All settings can be changed to suit individual requirements. The programming table indicates the factory settings. Changes to the existing settings can be easily made either before installation (e.g. temporarily power the unit with a PP3 battery) or by applying 12 volt to the unit on site. Once changes are made they are stored in the non-volatile memory. When power is applied the red indicator lights for 0.5 of a second.

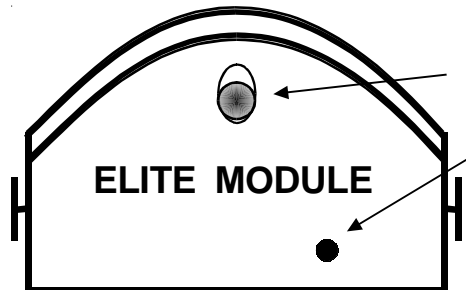

Dual red & green indicator

Program button

- 1) To enter program mode press and hold down the program button - the 'RED' indicator lights for 4 seconds then the 'GREEN' indicator sequences through the six 'selections'.
One flash for the range, **two** for pulse count. **Three** - LED monitor. **Four** - 'S' lux level. **Five** for CCTV mode and **six** to change the timer setting.
(see program chart Page 5)
- 2) When the required 'selection' is reached, release the button.
- 3) The 'red' led then flashes for the number representing the present 'option' setting.
- 4) If you want to change the present option setting - hold down the button again within 3 seconds. The red flashes will then sequence through the options available for that selection. Release when the number of red flashes corresponds to your option.
- 5) The Program mode exits after 3 seconds - all amendments are stored in the non-volatile memory.

Example 1: Altering the range from 20 metres to 35 metres.

Hold down the program button. The 'red' indicator lights - keep held until the 'green' led flashes once then release - the red led will flash three times - hold again until four red flashes, then five red flashes - then release.

Example 2: Altering the CCTV/Video output mode from mode 6 to mode 1.

Hold down the program button. The 'red' indicator lights - keep held until the sequence of five 'green' flashes then release - the red led will flash six times - hold again until seven red, then one red flash then release.

ELITE PROGRAM TABLE

HIGHLIGHTED BOXES ARE THE FACTORY SETTINGS

| | | | | | | | | | | | |
|-------------------------|--------------------|------------------------------|---------------|--------------|---------------|--------------|---------------|------------|------------|--------------|-----------|
| GREEN SELECTIONS | 1x | RANGE - MTRS (APPROX) | 10 | 15 | 20 | 28 | 35 | | | | |
| | 2x | PULSE COUNT | 1 | 2 | 3 | 4 | | | | | |
| | 3x | LED MONITOR | OFF/TP | ON/TP | OFF/NT | ON/NT | OFF/LO | | | | |
| | 4x | 'S' OUTPUT LUX LEVEL | 2 | 5 | 25 | 30 | 60 | 120 | 240 | 24 HR | |
| | 5x | CCTV/VIDEO MODE | 1 | 2 | 3 | 4 | 5 | 6 | 7 | | |
| | 6x | TIMER CCTV/VIDEO | 2 | 5 | 10 | 15 | 20 | 25 | 30 | 45 | 60 |
| | RED OPTIONS | | 1x | 2x | 3x | 4x | 5x | 6x | 7x | 8x | 9x |

Range

The range of the detector can be set from 10 to 35 metres. See the multibeam lens data on page 3 for masking off areas to reduce the range further or per ally requirements.

Pulse Count

The number of beams that have to be crossed before activation.

- 1 - will give a fast response
 - 2 - gives good immunity & response
 - 3 - gives high immunity to false alarms
 - 4 - slow response use in areas with poor environments(e.g. excessive foliage)
- The unit detects the changes in heat and movement in the beam pattern area, therefore trees, shrubs, ponds, boiler flues and animals should be considered when positioning the detector.

LED Monitor

- OFF/tp Detection indicator 'off' select this when requiring Tamper outputs with mode 1 and mode 7
- ON/tp Detection indicator 'on' select this option when requiring

- Tamper outputs with mode 1 and mode 7 (see page 6)
- OFF/nt The indicator is 'off' - both CCTV & Video outputs activate on detection.
- ON/nt The indicator is on - both CCTV and Video outputs activate on detection.
- OFF/lo Low power mode Supply 5mA- only the 'A' and 'S' output operate - no led indication.

'S' Output

The light level that the 'S' -ve output operates. The factory setting is '5' lux. This is generally considered the average light level at dusk. 24 HR activates the 'S' output irrespective of light level.

CCTV/Video Mode

There are seven different normally open and normally closed modes that the 24 hour volt free contacts can be utilised. See page 6 for these options.

Timer CCTV/Video

The timer settings available for the CCTV and Video volt free outputs

VOLT FREE OUTPUTS CCTV, VIDEO, & TAMPER

| MODE | VOLT FREE OUTPUT | STATE | ACTION ON DETECTION |
|---------------|--|------------------------|---|
| Mode 1 | CCTV | Normally Open | will close for the TIMER period after detection. |
| | TAMPER e.g.MUX and Alarm panel option | Normally Closed | remain closed on detection. Utilise the Video connections for tamper loop. The output will also open for 2 seconds if the front cover is removed. |
| Mode 2 | CCTV | Normally Open | will close for the TIMER period after detection. |
| | VIDEO | Normally Open | will close for the TIMER period after detection. |
| Mode 3 | CCTV (Factory Settings) | Normally Open | will close for the TIMER period after detection |
| | VIDEO (Factory Settings) | Normally Closed | will open for the TIMER period after detection. |
| Mode 4 | CCTV | Normally Open | will close for 0.4 second every time a detection takes place. |
| | VIDEO | Normally Closed | will open for the TIMER period after detection |
| Mode 5 | CCTV | Normally Open | will close for 0.4 second and can only re-trigger with detection after 4 seconds of non-activity. |
| | VIDEO | Normally Closed | will open for the TIMER period after detection |
| MODE 6 | CCTV | Normally Open | will close for 0.4 second and can only be retriggered every 4 seconds with detection. |
| | VIDEO | Normally Open | will close for the TIMER period after detection. |
| Mode 7 | CCTV | Normally Closed | will open for the TIMER period after detection |
| | TAMPER e.g.MUX and Alarm panel option | Normally Closed | remain closed on detection. Utilise the Video connections for tamper loop. The housing is pressure regulated - the output will also open for 2 seconds if the front cover is removed. |

INSTALLATION

During installation the electronics must be protected against water, as trapped moisture can effect or damage the unit.

- 1) First remove the front polythene cover by pulling forwards, then remove the lens module by pulling it out of the forked bracket.
- 2) Drill the wall to accept the top fixing and the lower cable entry. The holes should be on 16mm centres.
- 3) Feed standard 8 core alarm cable into lower cable entry; bare the wires and connect to the removable terminal block.
- 4) Always ensure when replacing the module that it is the correct way up for the correct alignment of the beam pattern. (page 3 multibeam lens data)
- 5) Replace the front cover with the ventilation hole at the bottom. Ensure the cover engages both sides of the outer casing before pressing firmly to locate it securely.

At this stage the unit can be walk tested with the front cover fitted. Use the program table on page 5 to adjust the range as necessary and pan and tilt the lens module over the field of view to obtain the correct coverage area.

TESTING USING A METER

Testing the volt free contacts - as the Elite has an integral 80R series resister the meter should be set to greater than 100 ohms rather than a continuity test setting.

WALK TEST

Alignment of detection beams.

The range of the detector increases without the front protective cover. Therefore the front cover must be fitted to establish the correct beam pattern alignment and when testing the outputs. When the 'program' button is pressed momentarily the red indicator lights and pulse count '1' is automatically selected. The unit can then be aligned. The red indicator will light on the Elite every time a detection takes place. This test mode will automatically cancel five minutes after last detection. Alternatively, remove the power and then re-apply.

If automatic lighting is required to illuminate the area during recording, the Elite PIR connects directly into any of the GJD lighting controllers for simultaneous recording and automatic lighting at dusk. The signals from the detector also provide an audible and visual indication of detection activity 24 hours a day. As the controllers also have a pulse count option, this must be set to '1' on the controller when using the Elite PIR for event recording.

ELITE APPLICATIONS

STANDARD WIRING

Video and CCTV outputs active on detection 24 hours a day
see page (6) for configurations of normally open or normally closed contacts. Mode-2 to Mode-6

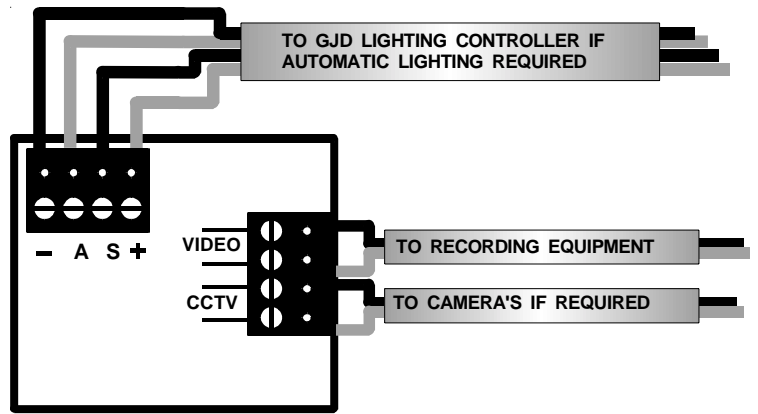

MUX APPLICATION:

When tamper is required select either
Mode-1 Normally Open - CCTV/Alarm
Normally Closed - Tamper

or

Mode-7 Normally Closed - CCTV/Alarm
Normally Closed - Tamper
select LED OFF/tp or LED ON/tp

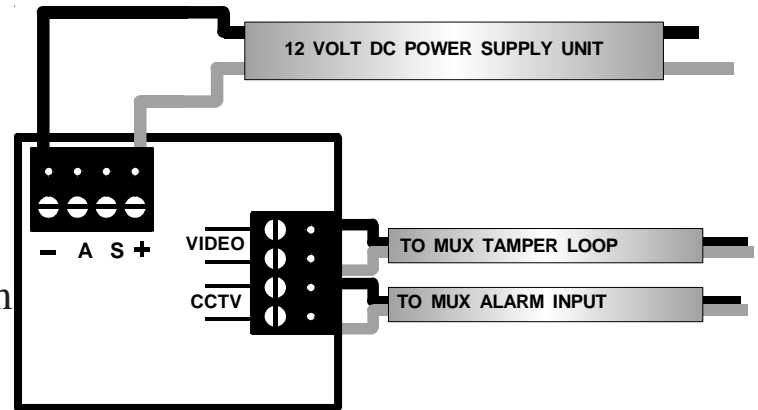

ALARM PANEL:

When tamper is required select either:
Mode-1 Normally Open - CCTV/Alarm
Normally Closed - Tamper

or

Mode-7 Normally Closed - CCTV/Alarm
Normally Closed - Tamper
select LED OFF/tp or LED ON/tp

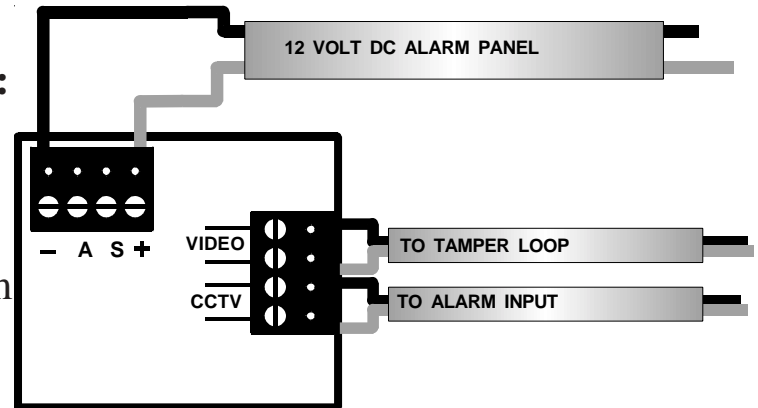

STANDARD

Standard wiring - two pairs of 24 hour
voltage free outputs combined with infra
red lighting activated at dusk for 60
seconds after last detection.
Mode-2 to Mode-6

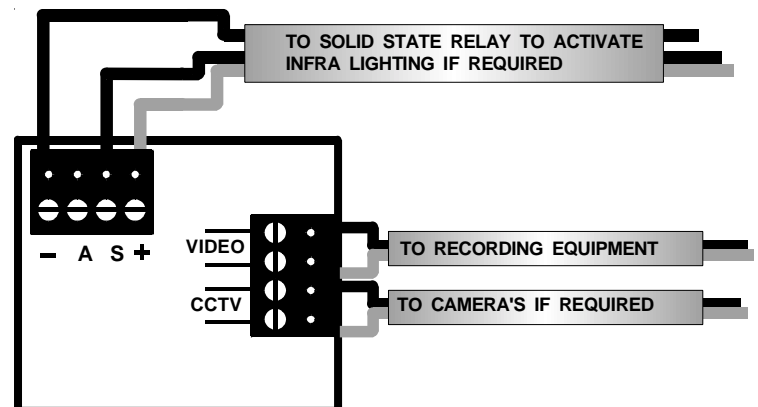

GJD reserve the right to amend specifications without prior notice

Technical: 01706 363990 Sales: 01706 363998 Fax: 01706 363991 Email: info@gjd.co.uk GJD Manufacturing Limited ©